

PRESS BRAKE SPECIFICATIONS

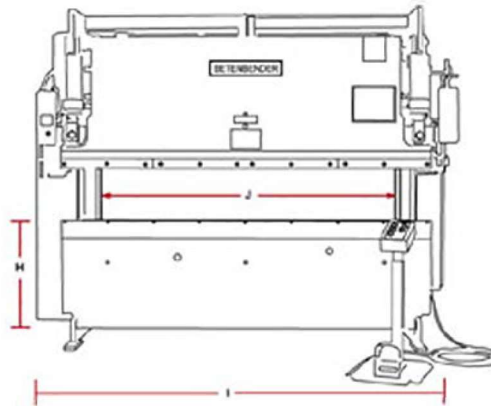
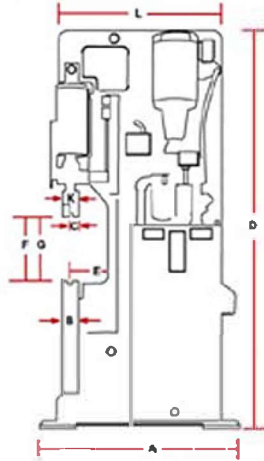

Please note:
ALL measurements
and weights
can vary from the
figures given in this
Specification Chart

HP	AMPS	
	208/230	460
10	28	14
20	54	27
30	80	40
40	104	52

- All dimensions are in inches.
- Engineering data and dimensions in this graph are subject to change without notice, due to continuing product development.
- Upon request, foundation plans will be furnished.
- Die Blocks are not furnished.
- To Convert Horespower to KW, multiply by 0.746.

**** ESTIMATED WEIGHTS.** The weight of your machine may vary from the estimated weight listed here. Weights may vary according to options included.

A Overall Width	E Throat Depth	I Overall Length	L Width of Upper End Plates	O Return to Open (IPM)
B Width of Bed	F Open Height	J Distance Between Housing	M Press (IPM)	P 2-Speed Electric Shift
C Width of Upper Machined Ram	G Closed Height	K Width of Upper Ram	N Rapid Approach (IPM)	
D Overall Height	H Height of Bed			

MODEL	A	B	C	D	E	F	G	H	I	J	K	L	M	N	O	P	HP	Wts**
4'-17	54	2	1 3/4	72	7	14	8-10	29-33	54	30 1/2	2	50	0-66	66	92	Std.	5	2,500
4'-50	45	2	1 3/4	104	8	12	6	28	63	30 1/2	2	36	0-66	66	92	Std.	10	5,800
6'-50	45	2	1 3/4	104	8	12	6	28	87	54 1/2	2	36	0-66	66	92	Std.	10	6,800
8'-50	45	2	1 3/4	104	8	12	6	28	111	78 1/2	2	36	0-66	66	92	Std.	10	8,000
10'-50	45	4	1 3/4	104	8	12	6	28	135	102 1/2	2	36	0-66	68	92	Std.	10	11,000
12'-50	45	4	1 3/4	104	8	12	6	28	159	126 1/2	2	36	0-66	66	92	Std.	10	12,500
4'-70	45	2	1 3/4	104	8	12	6	28	63	30 1/2	2	36	0-44	44	63	Std.	10	7,500
6'-70	45	2	1 3/4	104	8	12	6	28	87	54 1/2	2	36	0-44	44	63	Std.	10	8,000
8'-70	45	2	1 3/4	104	8	12	6	28	111	78 1/2	2	36	0-44	44	63	Std.	10	11,000
10'-70	45	4	1 3/4	104	8	12	6	28	135	102 1/2	2	36	0-44	44	63	Std.	10	13,000
12'-70	45	4	1 3/4	104	8	12	6	28	159	126 1/2	2	36	0-44	44	63	Std.	10	14,500
14'-70	45	4	1 3/4	104	8	12	6	28	183	150 1/2	2	36	0-44	44	63	Std.	10	15,500
6'-95	56 1/2	4	2 1/4	103	8	14	6	37	100	54 1/2	2 1/2	50	50	114	168	Std.	20	13,000
8'-95	56 1/2	4	2 1/4	103	8	14	6	37	123	78 1/2	2 1/2	50	50	114	168	Std.	20	18,000
10'-95	56 1/2	4	2 1/4	103	8	14	6	37	135	102 1/2	2 1/2	50	50	114	168	Std.	20	20,100
12'-95	56 1/2	4	2 1/4	103	8	14	6	37	159	126 1/2	2 1/2	50	50	114	168	Std.	20	21,000
14'-95	56 1/2	4	2 1/4	103	8	14	6	37	183	150 1/2	2 1/2	50	50	114	168	Std.	20	23,000
16'-95	56 1/2	4	2 1/4	103	8	14	6	37	207	174 1/2	2 1/2	50	50	114	168	Std.	20	24,000
6'-120	56 1/2	5	2 3/4	103	8	14	6	37	100	54 1/2	3	50	40	87	115	Std.	20	17,000
8'-120	56 1/2	5	2 3/4	103	8	14	6	37	123	78 1/2	3	50	40	87	115	Std.	20	19,000
10'-120	56 1/2	5	2 3/4	103	8	14	6	37	135	102 1/2	3	50	40	87	115	Std.	20	22,000
12'-120	56 1/2	5	2 3/4	103	8	14	6	37	159	126 1/2	3	50	40	87	115	Std.	20	24,000
14'-120	56 1/2	5	2 3/4	103	8	14	6	37	183	150 1/2	3	50	40	87	115	Std.	20	26,000
16'-120	56 1/2	5	2 3/4	103	8	14	6	37	207	174 1/2	3	50	40	87	115	Std.	20	28,000
8'-180	56 1/2	5	2 3/4	103	8	14	6	37	100	64 1/2	3	60	31	68	96	Std.	20	17,000
8'-180	88 1/2	5	2 3/4	103	8	14	6	37	123	78 1/2	3	60	31	68	96	Std.	20	19,000
10'-180	56 1/2	5	2 3/4	103	8	14	6	37	135	102 1/2	3	60	31	68	96	Std.	20	22,000
12'-180	56 1/2	5	2 3/4	103	8	14	6	37	159	126 1/2	3	60	31	68	96	Std.	20	24,000
14'-180	56 1/2	5	2 3/4	103	8	14	6	37	183	150 1/2	3	60	31	68	96	Std.	20	26,000
6'-190	56 1/2	5	2 3/4	103	8	14	6	37	100	54 1/2	3	50	25	55	66	Std.	20	17,000
8'-190	56 1/2	5	2 3/4	103	8	14	6	37	123	78 1/2	3	50	25	55	66	Std.	20	19,000
10'-190	56 1/2	5	2 3/4	103	8	14	6	37	145	102 1/2	3	50	25	55	66	Std.	20	22,000
12'-190	56 1/2	5	2 3/4	103	8	14	6	37	159	126 1/2	3	50	25	55	66	Std.	20	25,000
14'-190	56 1/2	5	2 3/4	103	8	14	6	37	183	150 1/2	3	50	25	55	66	Std.	20	27,000
6'-240	56 1/2	5 1/2	3 3/4	111	8	14	8	37	100	54 1/2	4	60	25	50	70	Std.	30	23,000
8'-240	56 1/2	5 1/2	3 3/4	111	8	14	8	37	123	78 1/2	4	60	25	50	70	Std.	30	26,000
10'-240	56 1/2	5 1/2	3 3/4	111	8	14	8	37	135	102 1/2	4	60	25	50	70	Std.	30	29,000
12'-240	56 1/2	5 1/2	3 3/4	111	8	14	8	37	159	126 1/2	4	60	25	50	70	Std.	30	33,000
14'-240	56 1/2	5 1/2	3 3/4	111	8	14	8	37	183	150 1/2	4	60	25	50	70	Std.	30	35,000
6'-300	56 1/2	5 1/2	3 3/4	118	8	14	8	37	100	54 1/2	4	60	25	50	70	Std.	30	29,000
8'-300	56 1/2	5 1/2	3 3/4	118	8	14	8	37	123	78 1/2	4	60	25	50	70	Std.	30	31,000
10'-300	56 1/2	5 1/2	3 3/4	118	8	14	8	37	135	102 1/2	4	60	25	50	70	Std.	30	34,000
12'-300	56 1/2	5 1/2	3 3/4	118	8	14	8	37	159	126 1/2	4	60	25	50	70	Std.	30	37,000
14'-300	56 1/2	5 1/2	3 3/4	116	8	14	8	37	183	150 1/2	4	60	25	50	70	Std.	30	38,000
10'-350	56 1/2	5 1/2	3 3/4	119	8	14	8	37	135	102 1/2	4	60	25	50	70	Std.	30	35,000
12'-350	56 1/2	5 1/2	3 3/4	119	8	14	8	37	159	126 1/2	4	60	25	50	70	Std.	30	37,000
14'-350	56 1/2	5 1/2	3 3/4	119	8	14	8	37	183	150 1/2	4	60	25	50	70	Std.	30	39,000